

AUTOMAC 55+

WRAPPING MACHINE

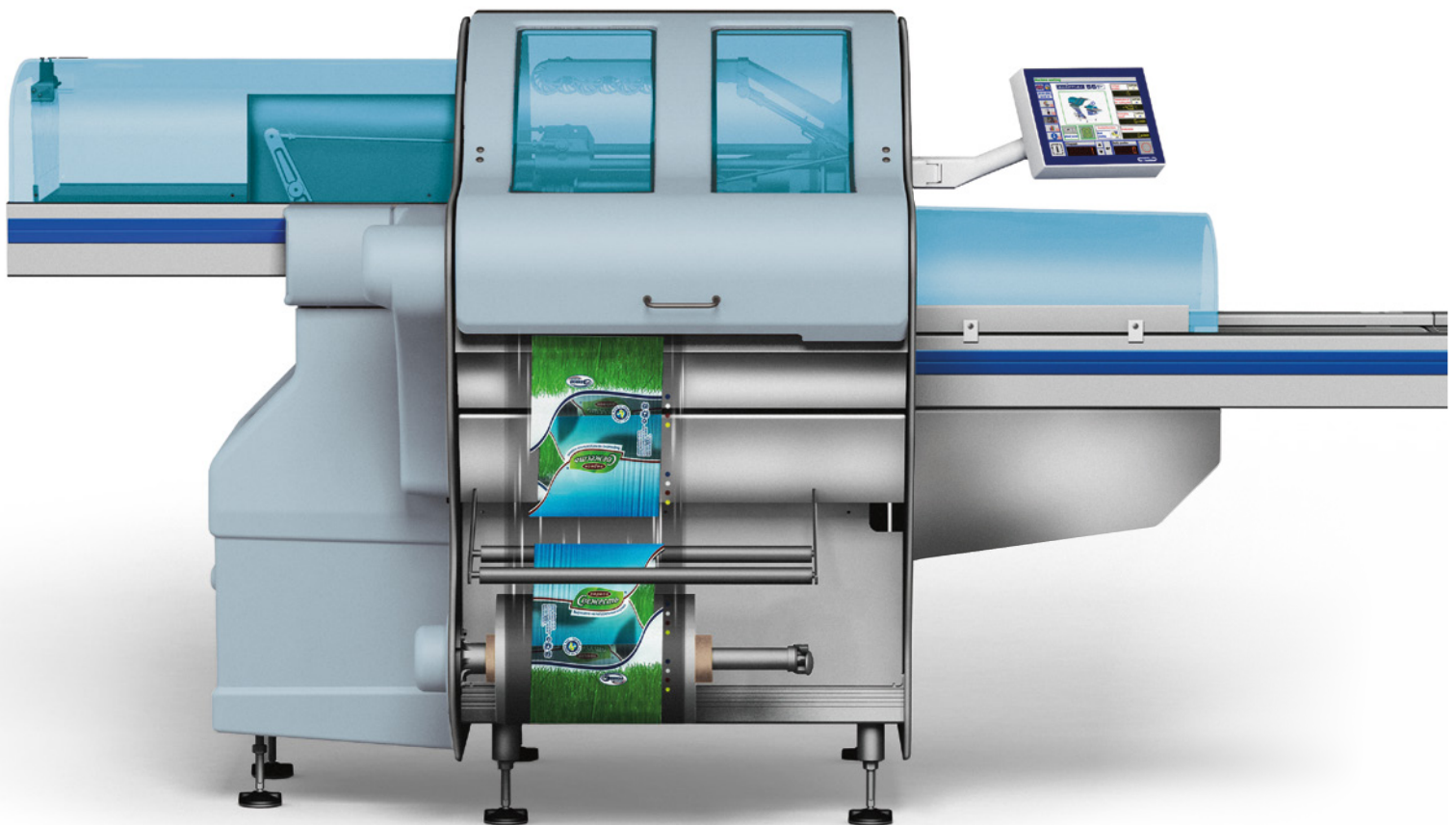

DE

Dehnfolienmaschine

- Schnell und flexibel, von 25 \rightarrow 55 V/min
- Einfache Bedienung über Touchscreen Display
- Neues Sicherheitspaket
- Neue Elektronik

IT

Filmatrice

- Veloce e flessibile, da 25 \rightarrow 55 c/min
- Facile utilizzo tramite schermo touch-screen
- Nuovo pacchetto di sicurezza
- Nuova elettronica

EN

Wrapping machine

- Fast and flexible, up to 25 \rightarrow 55 p/min
- Easy operation with Touchscreen Display
- New security package
- New electronics

AUTOMAC 55+

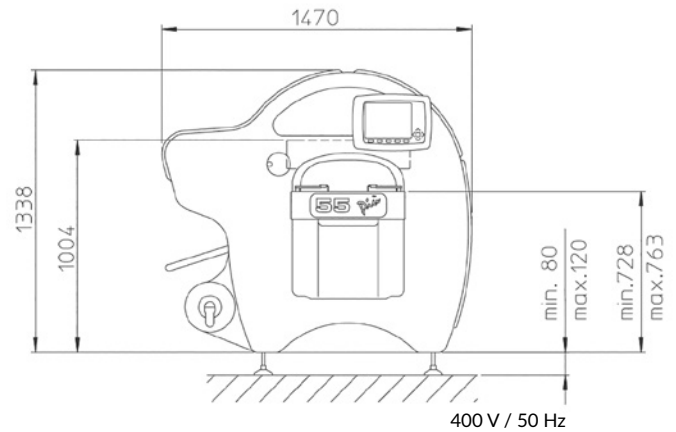
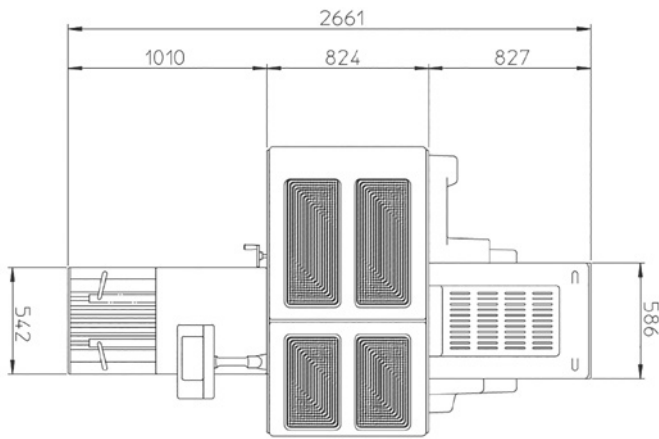

Touchscreen-Monitor mit 29 editierbaren Programmen
Nuovo monitor touch-screen, fino a 29 programmi modificabili
New touch-screen monitor, up to 29 editable programmes

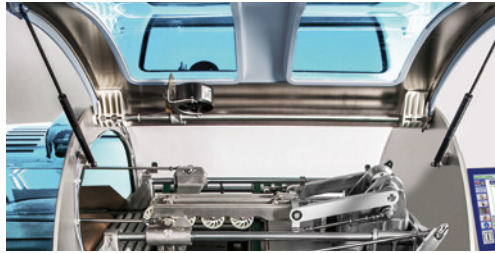

Flügel Türen-Öffnung - NO LIMIT Zugang
Apertura ad ali di gabbiano - accesso NO LIMIT
Gullwing opening of the top carters - NO LIMIT access



Neue Sicherheits-Standards
Nuovi standard di sicurezza
New security standards

DE

TECHNISCHE MERKMALE

- 45** Formatwechsel:
45 Sekunden
- 25** ↓
55 p/min Geschwindigkeit 25 bis 55
Verpackungen pro Minute
Optimale Long-life Geschw.: 45/50
- 29** Verfügbar Verpackungs-
programme : 29
- 120** Schalenformat min.
(L x B x H mm)
Mit Hubtisch E
120 x 120 x 10
- 320** Schalenformat max.
(L x B x H mm)
Mit Hubtisch E
230 x 320 x 200*
- 180** Schalenformat min.
(L x B x H mm)
Mit Hubtisch A
180 x 180 x 10
- 400** Schalenformat max.
(L x B x H mm)
Mit Hubtisch A
260 x 400 x 200*
- 330** Stretchfolie Rollenbreite min.
330 mm
- 550** Stretchfolie Rollenbreite max.
550 mm

IT

CARATTERISTICHE

- Cambio formato:**
45 secondi
- Velocità da 25 a 55**
confezioni al minuto
Velocità long-life ottimale: 45/50
- Programmi di avvolgimento**
disponibili : 29
- Formato vassoio min.**
(L x l x H mm)
con sollevatore E
120 x 120 x 10
- Formato vassoio max.**
(L x l x H mm)
con sollevatore E
230 x 320 x 200*
- Formato vassoio min.**
(L x l x H mm)
con sollevatore A
180 x 180 x 10
- Formato vassoio max.**
(L x l x H mm)
con sollevatore A
260 x 400 x 200*
- Film estensibile larghezza bobina**
min. 330 mm
- Film estensibile larghezza bobina**
max. 550 mm

EN

SPECIFICS

- Changing format:**
45 seconds
- Speed from 25 to 55**
packages per minute
Optimal long-life speed: 45/50
- Available wrapping**
programmes : 29
- Min. tray format**
(L x W x H mm)
with E lifter
120 x 120 x 10
- Max. tray format**
(L x B x H mm)
with E lifter
230 x 320 x 200*
- Min. tray format**
(L x B x H mm)
with A lifter
180 x 180 x 10
- Max. tray format**
(L x B x H mm)
with A lifter
260 x 400 x 200*
- Stretch film. Min reel width**
330 mm
- Stretch film. Max reel width**
550 mm

* Es ist nicht möglich, die drei Maximalmaße für die Schale gleichzeitig zu erreichen | Non è possibile raggiungere le tre dimensioni massime del vassoio contemporaneamente. | It is not possible to achieve the three maximum dimensions of the tray at the same time.